

## Coupling hub engagement: No keyways, please!

It is no exaggeration to claim that keys and keyways have been used to attach machine components to shafts for well over a thousand years.



Properly designed and carefully fitted, keys and keyways will prove satisfactory in most applications. However, this engagement method represents a significant stress riser, which is to say that the overload capacity or safety factor of a shaft system is adversely affected.

Avoiding stress risers is one of the rules of machinery reliability improvement. Accordingly, knowledgeable equipment manufacturers often offer hydraulically fitted coupling hubs for major high-speed turbomachinery, and the "best-in class" user companies would specify hydraulic engagement as a matter of routine.

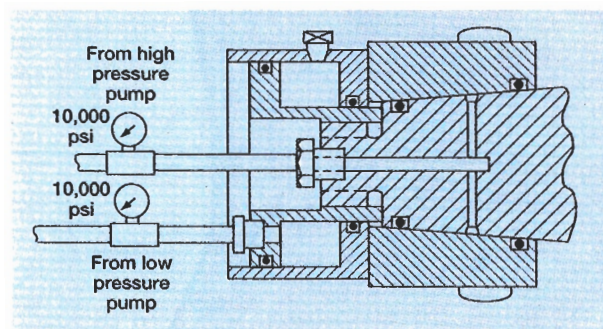

Fig. 1. Hub expansion fluid supplied through shaft center.

Two principal mounting geometries are generally found. These are shown in Figs. 1 and 2, where two separate hydraulic loops are used, to expand the hub bore and simultaneously push the coupling hub onto a tapered shaft end. In Fig. 1, the hub expansion fluid is supplied through the shaft center, whereas Fig. 2 depicts fluid application through porting transversely drilled into the coupling hub. In either case, hub bore and shaft taper must be precisely identical to achieve maximum holding power. The O-rings shown in both illustrations date back to 1960s technology when they were thought necessary for fluid containment. However, O-rings are not really necessary in the hub extension loop as long as proper machining tolerances and surface smoothness are maintained. Interference fits of 0.002 in. (mm) per in. (mm) of shaft diameter will prevent these keyless hubs from slipping under virtually all normal operating conditions imposed on modern turbomachines.

But what about cylindrical shaft ends, especially in retrofit applications? Here, the reliability professional might consider Coupling Corporation

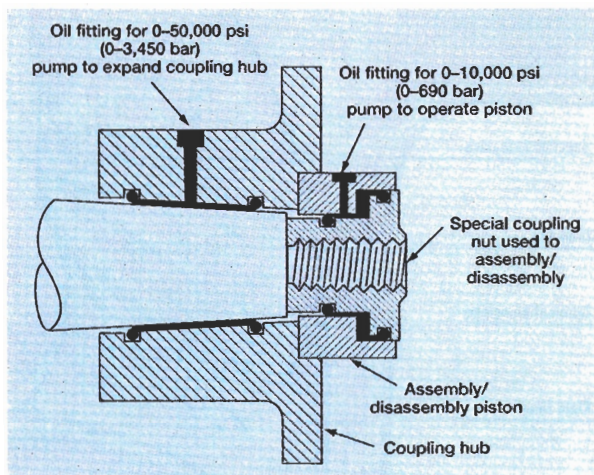

Fig. 2. Fluid supplied through drilled porting.

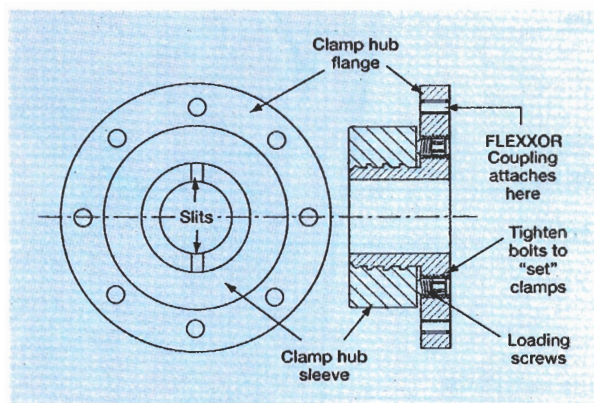

Fig. 3. "Anderson Hub Clamp."

of America's "Anderson Hub Clamp." This patented device (Fig. 3) is designed to accommodate most shafts, especially those with somewhat questionable surface smoothness. On retrofits, users have had particular success on straight, tapered, keyed and keyless shafts.

The system is based on an asymmetrical profile thread into the outside diameter of clamp hub flange (1) and the bore of clamp hub flange (2). When the installer torques the loading screws (3), a predetermined uniform force pushes the sleeve away from the flange. The special asymmetrical threads cause this axial force to exert a clamping action radially inward on the split sleeve portion of the clamp hub flange. It can be shown that the gripping action is sufficient to prevent slippage on virtually any machine shaft. ■

**Heinz P. Bloch** is a consulting engineer in Montgomery, Texas. He advises process plants worldwide on reliability improvement and maintenance cost reduction opportunities. His six books on machinery reliability improvement are available from Gulf Publishing Company.